

Rooftop solar power station system example

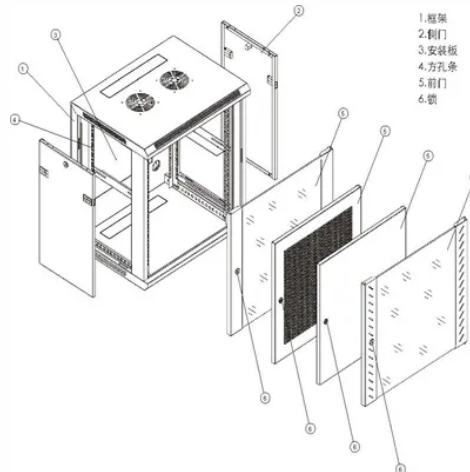

Overview

Most rooftop PV stations are Grid-connected photovoltaic power systems. Rooftop PV systems on residential buildings typically feature a capacity of about 5–20 kilowatts (kW), while those mounted on commercial buildings often reach 100 kilowatts to 1 megawatt (MW). Very large roofs can house industrial scale PV. A rooftop solar power system, or rooftop PV system, is a that has its -generating mounted on the rooftop of a residential or commercial building or structure. The various. Installation costPV system prices (2022)IncentivesUnited StatesSolar incentives by state in the USA can help offset the initial cost of installation and make solar power. A rooftop photovoltaic power station (either on-grid or off-grid) can be used in conjunction with other power components like,, batteries etc. These may be capable of providing a continuous source of. An electrical power system containing a 10% contribution from PV stations would require a 2.5% increase in (LFC) capacity over a conventional system —an issue which may be countered by using in the DC/AC-circuit of the PV. The urban environment provides a large amount of empty rooftop spaces and can inherently avoid the potential land use and environmental concerns. Estimating rooftop solar insolation is a multi-faceted process, as insolation values in rooftops are impacted by the. or photovoltaic shingles, are solar panels designed to look like and function as conventional roofing materials, such as or slate, while also producing electricity. Solar shingles are a type of solar energy solution known as Installers have the right to feed solar electricity into the public grid and hence receive a reasonable premium tariff per generated kWh reflecting the benefits of solar electricity to compensate for the current extra costs of PV electricity. For consumers, a solar.

Article Content

Rooftop solar Distributed Power Plants: A better way ...

This helps to prevent power outages, and turning on expensive and polluting peaker power plants. In return, solar owners earn compensation for the use of their investment. This is how DPPs can create the equivalent of a ...

Design, Simulation and Economic Analysis of A Rooftop Solar PV System ...

measured productivity of the solar power plant. Al Ali, M., and Emziane, M. evaluated the performance of seven different PV systems. The study showed that rooftop solar PV efficiency in Abu Dubai is feasible. Mounir Bouzguenda et al. designed, simulated and analysed an independent solar power system at King Faisal University.

Technical Analysis on Household-Scale Rooftop Solar Power Plant ...

the examples of the renewable energy application by taking advantage of the sun as the ... Therefore, the purpose of this research is to analyze technical feasibility of rooftop solar power plant system with a household-scale on -grid system by the PVSyst 6.43 software utilization. 2 Theoretical Background

Industrial Solar Rooftop System ...

Slide 45: Following slide shows performance tracking dashboard for solar power plant. It includes details such as consumption rate, daily production rate, electricity export & ...

Roof Top Solar Installation: A Case Study

This paper represents a case study of grid type solar panel on the roof top of block-7 at Chandigarh University, so that we can supply energy to grid when it's a holiday and if our consumption...

DESIGN AND IMPLEMENT OF 100 kW ROOFTOP GRID ...

This paper presents a new approach for optimum design and implement of rooftop grid connected PV system installation on an institutional building at Minia University, Egypt as a case study.

Towards better performances for a novel rooftop solar PV system ...

A novel PV plant design is developed here in order to improve the energetic efficiency of an existing PV ... rooftop solar PV system. For example, the SKY (Surya Shakti KisanYojana) project was directed to farmers, ... (2013) developed an optimal capacity allocation of standalone wind/solar/battery hybrid power . 136 . system using an improved ...

shortcomings will lead to cancelation of subsidy as decided by ...

b. Wiring up to Distribution Board from the SPV Rooftop system will be in the scope of the successful bidder(s). The maximum cable length of 25m for every solar power plant installed shall be in the scope of the bidder and supply of excess cable length if required shall be in the scope of purchaser. c. Performance testing of the complete ...

DETAILED PROJECT REPORT For Installation

The reputed make of the major equipments for standalone solar PV roof top system is provided in Annexure -V. AREA AVAILABILITY Roof Area Availability for Stand Alone Solar Power Plant. The total roof space available at Govt. ...

Design of a 50 kW solar PV rooftop system

Renewable energy resources become very popular and commonly used nowadays. An example of a clean renewable energy resource is the energy generated using photovoltaic (PV) systems. As a result of using PV as a renewable energy resource, components of PV such as an inverter become widely used for this purpose and in order to enhance the maximum obtained power ...

Design and Implementation of 1.43 MWp Grid-Connected Rooftop Solar ...

1.1 Grid-Connected Rooftop Solar PV System. Cost of conventional power through fossils fuels is the major challenge for Indian industries. In view of the current pandemic (COVID-19) situation, every industry is taking numerous initiatives for reduction of manufacturing cost and cost of power is one of the key barriers to achieve the same [].To control the cost of ...

What is Rooftop Solar Power Plant? | Solar Energy ...

What is a Rooftop Solar Power Plant? A rooftop solar power plant is a set of solar panels on a building's roof. It produces electricity from the sun. These systems are smaller than big solar farms, mainly for homes and ...

National Portal for Rooftop Solar

Hon''ble Prime Minister of India, Shri Narendra Modi launched the National Portal for Rooftop Solar on 30/07/2022. Shri R. K. Singh, Union Minister for Power and NRE and Shri Krishan Pal ...

Design of a 50 kW solar PV rooftop system

In the current work, a 105 kWp rooftop solar system is designed and installed to fulfil part of the electric ...

59 Solar PV Power Calculations With ...

Learn the 59 essential solar calculations and examples for PV design, from system sizing to performance analysis. ... These calculations help understand if the roof can support the PV ...

Rooftop photovoltaic power station

A rooftop photovoltaic power station, or rooftop PV system, is a photovoltaic (PV) system that has its electricity-generating solar panels mounted on the rooftop of a residential or commercial building or structure.

The Gantt chart for the construction of solar power ...

Gantt chart representing the installation of a rooftop solar installation of 100 kW. ... For example, "Starting an AC System" is a predecessor to the "Testing Commission of a Station Efficiency". ... only one day may delay ...

Project Report

The report presents detailed project report for feasibility study and detailed techno-economic assessment of solar PV rooftop power plant in GHMC area. Various buildings suitable for ...

Single-Phase Grid-Connected Solar ...

This example shows how to model a rooftop single-phase grid-connected solar photovoltaic (PV) system. This example supports design decisions about the number of panels and the ...

Successful Grid Connection of a 1MW Rooftop Distributed Power ...

A notable example of such a system is the successful grid connection of a 1MW rooftop distributed power plant. This project marks a significant achievement in renewable ...

An Example Sample Project Proposal on "Solar-Powered Schools ...

The purpose of this project proposal is to outline the implementation of solar-powered systems in schools, with a focus on harnessing renewable energy to power educational facilities. The integration of solar energy will not only reduce schools' carbon footprint but also provide valuable learning opportunities for students, fostering a culture of sustainability and environmental ...

Handbook for Rooftop Solar Development in Asia

To better illustrate how to implement the steps for implementing a rooftop solar PV system, this handbook provides examples from the Asian Development Bank's (ADB) own ...

TECHNICAL SPECIFICATIONS OF ON-GRID SOLAR PV POWER ...

and the commissioning of the PV Power Plant are coming under the scope of the EP company. 2. Location Rooftops of Residential, Public/Private Commercial/Industrial buildings, Local Self Government Buildings, State Government buildings. 3. Definition Solar PV power plant system comprises of C-Si (Crystalline Silicon)/ Thin Film Solar PV

Rooftop Solar PV, Coal Plant Inflexibility and the ...

But if such a cycle occurs continuously it will be accompanied by a slowly rising series of technical problems due to the cumulative loss of synchronous plant, viz. system strength shortfalls and falling inertia 2 ...

10 kwp-solar-rooftop-system | PDF

The document proposes a 10 KWp rooftop solar PV system for a site in New Delhi, India. It would include 50 200-watt solar panels producing an estimated annual output of ...

Schematic diagram of a typical solar PV ...

Zuhaib et al. (2021) studied a 3 MWp ground-mounted grid-tied solar power plant in Northern India and found that module temperature, wind speed, and dust accumulation are critical ...

Largest Rooftop PV list

We introduce the rating of the largest rooftop solar PV systems worldwide. The list includes the stations having a power capacity of 1MW and higher. Both the projects currently operating and the ones under development are listed. The catalogue has two additional sub-categories: single-site and multi-site installations.

Economic Feasibility Analysis of Rooftop Solar Power Plant ...

feasibility of rooftop solar power plant system with a householdscale on- - grid system i n Semarang City. Through PVSyst 6.43 and RetScreen software also equipped with several primary components, this household-scale rooftop solar power plant investment plan is estimated to have an average revenue return estimated in 10 years later.

Rooftop Solar Systems | PPT

Rooftop solar power provides feasible options for corporates and industries to save on energy costs. A rooftop solar power system installs solar panels on a building's ...

Case Studies

146 kW Rooftop Solar Power System - HMR Institute of Technology and Management KNOW MORE. Large Projects - Case Studies. Solutions for Businesses. ... 100MW Solar PV Power Plant with 40MW/120MWh Battery ...

Designing Solar PV Systems (Rooftops)

12. Solar PV system sizing 1. Determine power consumption demands The first step in designing a solar PV system is to find out the total power and energy consumption ...

Single line diagram of a 100 kWp solar rooftop PV ...

This paper presents the optimization of a 10 MW solar/wind/diesel power generation system with a battery energy storage system (BESS) for one feeder of the distribution system in Koh Samui, an ...

Application examples of solar power plants | AVENSTON

A solar photovoltaic power station was built in Ternopil on the roof of a manufacturing plant. The solar modules occupy an area of 1120 sq.m. PV plant type: rooftop, on-grid, for self-consumption.

MERC Introduces Virtual Net Metering for Rooftop Solar Power

SOLAR POWER PLANT & ROOFTOP SYSTEM; SOLAR HYBRID SYSTEM AND MICROGRID SOLUTIONS; BIPV, FACADE, ARCHITECTURAL SOLAR PANEL SYSTEMS; SOLAR TELECOM SOLUTIONS; ... Maharashtra MERC Introduces Virtual Net Metering for Rooftop Solar Power. on October 23, 2024 December 28, 2024 Share Facebook Twitter ...

A rooftop revolution: turning possibility into reality

Implementing roof-first planning policies that prioritise opportunities for generating solar energy from areas that are already built on, while avoiding land that is being viably and sustainably farmed. Changing ...

Classification of solar power plants (PV ...

Rooftop solar power plants (located on flat, pitched and other types of roofs) ... The photo shows an example of a floating solar power plant. ... Solar power plants for the sale of generated ...

100kW Solar Power System: Cost, Benefits, and Area ...

The cost of a solar power plant depends on multiple factors including brand and quality of equipment, plant location, roof orientation, inverter type, style of mounting structure, etc. For example, a grid-tie system that ...

Contact Us

For more information, pricing, or custom solutions, please contact us:

Website: <https://bethefuturefoundation.co.za>

Email: info@bethefuturefoundation.co.za

Phone: +27 82 415 7896

Address: The Campus, 57 Sloane Street, Bryanston, Johannesburg, 2021,
South Africa

This document is for informational purposes only. Specifications subject to
change without notice.

